

# OUTLINES AND DIMENSIONS

MS-GM19VA MS-GM23VA

Unit: mm

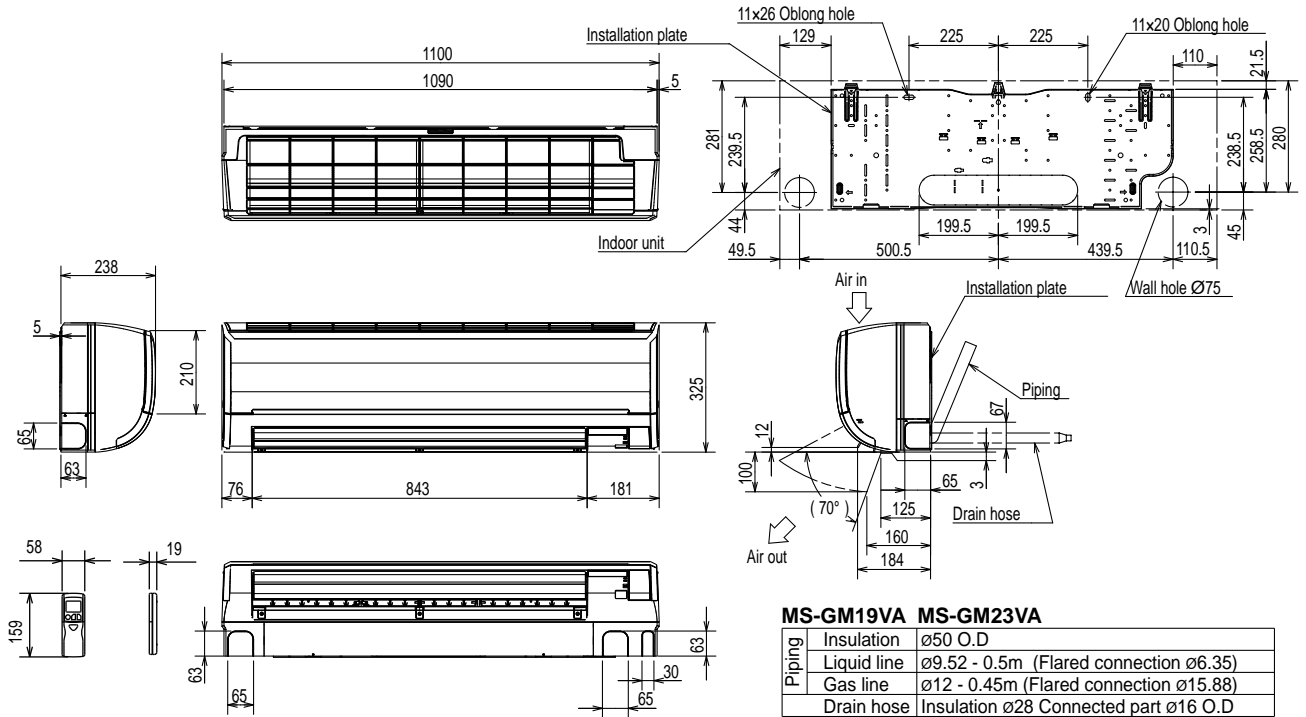

Gas pipe size dia12, use reducer to dia15.88 when connecting to outdoor

# OUTLINES AND DIMENSIONS

MU-GM19VA

Unit: mm

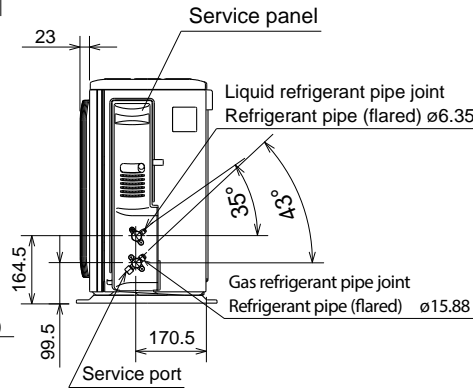
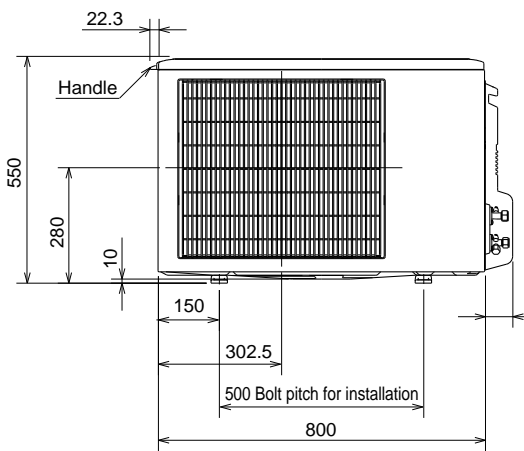
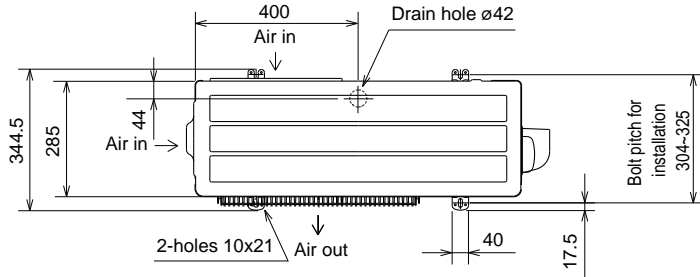

## REQUIRED SPACE

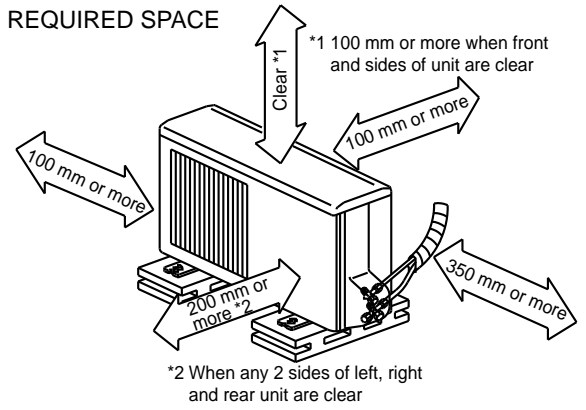

# OUTLINES AND DIMENSIONS

MU-GM23VA

Unit: mm

## REQUIRED SPACE

\*1 500 mm or more when front and sides of the unit are clear

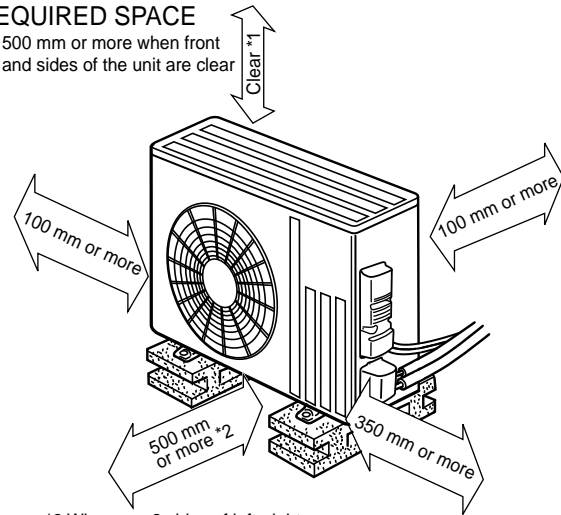
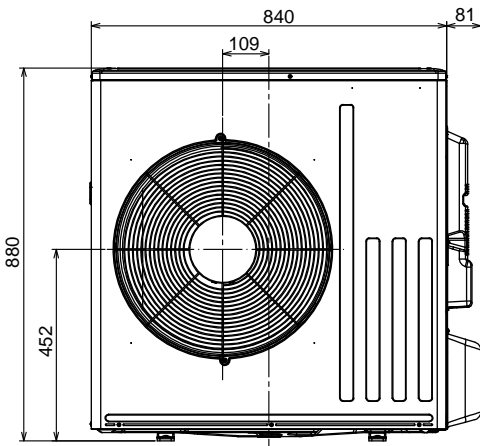
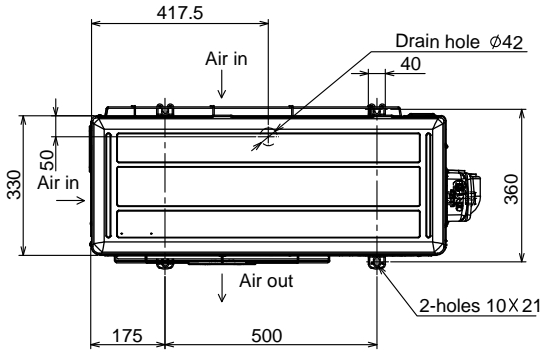

\*2 When any 2 sides of left, right and rear of the unit are clear

